

Once you complete this form, please return by fax (0296706744) or email (order@dincel.com.au).

ORDER DATE:		QUOTE NUMBER (IF ANY)	
ORDER NAME / NO:			
CUSTOMER'S NAME: <small>(See clause 1 below)</small>			A.C.N.
CUSTOMER'S ADDRESS:			STATE:
SITE ADDRESS:			STATE:
DELIVERY ADDRESS: <small>(If different to site address)</small>			STATE:
SITE CONTACT NAME:	EMAIL:		
SITE PHONE NO:			FAX NO:
ACCOUNTS CONTACT NAME:	EMAIL:		
ACCOUNTS PHONE NO:			FAX NO:
DELIVERY METHOD:	DELIVERY TO SITE <small>(Sydney, Melbourne & Brisbane metro. Contact us for other areas)</small> <input type="checkbox"/>		LOCAL PICKUP <small>(Sydney, Melbourne & Brisbane)</small> <input type="checkbox"/>

MAIN PROFILE - 275P-1

(275mm x 275mm)

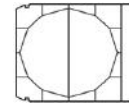

275P-1 profiles are produced at stock heights of 3000mm & 3600mm & custom heights between 1800mm & 6525mm. **275mm profiles are only available in 75mm increments.** Custom heights have a minimum order quantity of 6 panels. Please contact the customer service team on (02) 9670 1633 to confirm stock availability and current lead times.

	HEIGHT (mm)	QTY		HEIGHT (mm)	QTY
STOCK 1	3000		CUSTOM 3		
STOCK 2	3600		CUSTOM 4		
CUSTOM 1			CUSTOM 5		
CUSTOM 2			CUSTOM 6		

ACCESSORIES

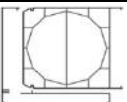
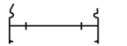
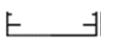
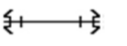
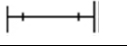
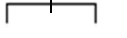
MODULE	(mm)	QTY
275P-3 	3600	
275P-4 	3600	
275P-EC 	3600	
275P-J 	3600	
275P-WS 	3600	
275P-TC* 	3600	

NOTE: The notches on the above accessory diagrams indicate the panel has pre-drilled holes

*Can be snapped in half to create 2 angles

- (1) Customer means the person and/or company name that appears on the Dincel Order Form.
- (2) I confirm that I have read and understood the DCS 'Terms & Conditions of Sale' document which is attached to this order form & also available on the DCS website.
- (3) I confirm that the heights and quantities nominated in this order are correct.
- (4) I understand that DCS will not accept any returns of the unused product and no refunds will be made.
- (5) The requested delivery date noted below will be confirmed by DCS once the deposit payment is made.
- (6) If the Australian Dollar falls below US90cents, the charge may need to be increased on a pro-rata basis.
- (7) I hereby certify that I have the legal capacity to purchase the goods named herein and sign this Order Form on behalf of the customer named herein.

.....
 Full Name in Block Letters

.....
 Signature

.....
 Requested Delivery/Pickup Date

(To be confirmed by DCS)

Telephone: (02) 9670 1633
 Facsimile: (02) 9670 6744

101 Quarry Rd, ERSKINE PARK, NSW, 2759
 PO Box 104, ST CLAIR, NSW, 2759

Email: order@dincel.com.au
 A.B.N. 78 083 839 614

ORDER RECEIVED (OFFICE USE ONLY) :

TERMS AND CONDITIONS OF SALE

1. TERMS AND CONDITIONS

1.1 These Terms and Conditions shall apply to all Products and Services manufactured or supplied or sold by DCS. These terms shall apply notwithstanding any provisions to the contrary which may appear on any document issued or supplied by the Customer or any other party.

2. DEFINITIONS

2.1 In these Terms and Conditions of Sale:

- *"Agreement"* refers to any agreement between DCS and the Customer whereby the Customer orders and DCS agrees to supply Goods and Services to the Customer. The terms of the Agreement shall include these Terms and Conditions and any other terms and conditions specified by DCS.
- *"Australian Consumer Law"* means The Australian Consumer Law forming part of the Competition and Consumer Act 2010.
- *"COD"* refers to payments on delivery or collection of goods in cleared funds.
- *"Consumer"* has the same definition as that contained in the Competition and Consumer Act 2010. The Dincel Products are sold and/or supplied for commercial purposes and are not deemed to be Consumer products.
- *"Credit"* means the supply of Goods or services before payment. Applicable to approved Customers with minimum purchase quantity. Credit Account and Credit Account Customers is used in this document to identify Customers who been granted a Credit arrangement by DCS.
- *"Custom Lengths"* means any Goods and/or Product which, at DCS's sole discretion, deviates from standard sizes and/or dimensions.
- *"Customer"* means any entity which enters into an Agreement with DCS including the Customer's employee or agents
- *"DCS"* means Dincel Construction System Pty Ltd. ACN 083 839 614
- *"Goods"* means all Products, components and related accessories manufactured or supplied or sold by DCS from time to time. The terms "Products" and "Goods" are used interchangeably.
- *"Entity"* means a person(s), firm, partnership, corporation, trust, joint venture or any trader of any description.
- *"PPSA"* means the Personal Property Securities Act 2009 (Cth) as amended from time to time. Where the context admits, a term used in these Terms and Conditions has the same meaning as in the PPSA.
- *"Quotation of Rates"* means a written quotation from DCS of a supply rate and/or pricing for the Customer in respect of a particular project.
- *"Order"* refers to Customer's request for the supply of the Product/s by filling in the DCS Order Form(s)
- *"Services"* includes, but is not limited to, any other services rendered to the Customer by DCS, its agent, employee or servant from time to time.
- *"Stock Lengths"* means any Goods/Product which is not Custom Lengths.

3. DISCLAIMERS

- 3.1 It is the responsibility of the Customer to ensure that the Products purchased from DCS is installed by a competent tradesperson who is familiar with formwork and concrete installation.
- 3.2 **The Dincel Construction Manual for Designers and Builders and other buildability detailing shown in the Dincel website is provided for guidance only.** The project specific construction detailing associated with the use of Dincel Products is the responsibility of the Customer's building professionals. **It is the customer's responsibility to obtain the current Construction Manual from DCS.**
- 3.3 Whilst builders might, for expediency, manage discrepancies between on-site and planned dimensions by cutting, replacing with an alternative Dincel Product or extending the Product by use of conventional formwork, neither DCS nor any professional associated with DCS will not be liable for any loss or damage for such adaptation or improvisation and such departure shall be entirely at the discretion and risk of the Customer.
- 3.4 Suitability including construction detailing and installation procedures for the use of the Product on the project for which the Product is ordered must be determined by the Customer's own Engineers/Consultants and DCS will not be liable for any loss or damage should the Product be found to be inappropriate for the project and/or should the Product be used for any purpose other than that for which the Product was specifically designed and intended.
- 3.5 The consideration of combustibility at façade walls and the use of fire collars and fire seals at abutting walls (Dincel to Dincel or Dincel to any other fire rated walls) may be required on and/or within Dincel Walls and/or columns. DCS sells the Dincel product based on the conclusions of the Fire Performance Solution prepared by AED Fire Engineers. It is the responsibility of the Customer to obtain the AED Report if required which is available to all DCS customers.

4. DESCRIPTIONS OF DCS PRODUCTS AND SAMPLES

- 4.1 All physical samples and descriptions, specifications, illustrations, drawings, data, dimensions and weights in respect of the Goods contained in catalogues, manuals or other DCS material are approximate only, and are only intended by DCS to be a general description.
- 4.2 DCS may produce Goods with minor modifications from any of its samples, drawings and specifications.
- 4.3 DCS is not liable to the Customer for any loss or damage suffered by the Customer as a result of the Customer relying upon any such specifications, illustrations, drawings, data, dimensions, weights or the characteristics of any samples.

5. GENERAL

- 5.1 Any oral representation, warranty or promise whatsoever (other than those contained herein) made by any servant or agent of DCS to the Customer does not form any part of the Agreement nor the consideration for or basis of any collateral contract.
- 5.2 Subject to any express consent in writing of DCS, a waiver by DCS of a default in the strict and literal performance of any provision of these Terms and Conditions shall not be deemed to be a waiver of strict and literal performance of any other provisions of this agreement, nor to be a waiver of strict and literal performance of that provision in the future, nor in any manner to impair the exercise of any such rights accruing to it thereafter.
- 5.3 No Quotation of Rates given by DCS shall constitute a binding offer. DCS's written acceptance of an Order shall create a legally binding contract for the supply of the Goods on the terms of the Agreement.
- 5.4 DCS reserves the right to decline any Order or to enter any supply Agreement.
- 5.5 If a Customer cancels or alters any order for Products after DCS has received an order then DCS reserves the right to charge to the Customer the additional costs incurred in cancelling or altering any order or part order together with the costs of any labour and handling to the date of such cancellation or alteration.
- 5.6 Any notice in connection with these Terms and Conditions or any Agreement will be deemed to have been duly given when made in writing and delivered or sent by facsimile or post or by email to the party to whom such notice is intended to be given, at the address including email address or facsimile number of that party or to such other address or facsimile number as may from time to time be notified in writing to the other party. In the case of mail, delivery shall be deemed to have occurred 3 days after posting and in the case of facsimile and email, upon the day of transmission.
- 5.7 A reference to dollars is to Australian Dollars
- 5.8 These Terms and Conditions do not create a relationship of agency, partnership, joint venture or employment between the parties. Neither party has any authority to act for or incur any liability or obligation on behalf of the other party in any manner.

6. SALE, PRODUCT WARRANTY, PRODUCT ACCEPTANCE

- 6.1 Any claim for discrepancies relating to Goods delivered or collected must be made immediately upon receipt of the Goods. No claim will be accepted once the delivery or collection of Goods has been accepted.
- 6.2 Any agreement between the Customer and DCS relating to the sale, purchase and any other dealings with respect to the Goods must be in writing. No verbal agreement/s will be accepted by DCS.
- 6.3 Product quality checks are undertaken as DCS is an ISO – 9001 quality endorsed company. Upon delivery of the Goods by DCS or collection by the transportation company organised by the Customer, DCS requires proof of delivery or collection dockets to be signed by the Customer's authorised representative or authorised agent acknowledging that the Product received is Non-Defective. The Customer agrees and will ensure that all Goods received or collected must be signed by an authorised representative or authorised agent of the Customer. The Customer agrees and warrants that the transportation company nominated by the Customer to collect Goods from DCS acts as agent on behalf of the Customer and is authorised to sign and acknowledge that the Goods are Non-Defective upon collection.
- 6.4 Any Product claimed to be Defective by the Customer or its representative or agent at the time of delivery to or collection by the Customer, and after final confirmation by DCS, may be replaced. The word Defective shall only refer to Goods/Products that display punctures or Products that are significantly distorted and such profiles that are unable to snap-clip to each other. Dincel Products are sold for formwork purposes and not intended to be used as a finished product. Customer/s who intend to use the installed Dincel Product as a finished wall hereby accept the Dincel Product complying with Class 2 to 4 finish of AS3610 Formwork Code or alternatively have the option to apply paint, render or cladding to achieve their desired finish. Any colour variation between panels delivered to site shall not constitute a Defective Product. Non-Defective shall refer to Goods/Products that are not Defective.
- 6.5 The Customer agrees that upon delivery or collection of the Goods unless the Goods are claimed at that time to be Defective and this is subsequently confirmed by DCS in accordance with clause 6.4, the Goods will be Non-Defective and the Customer may not make a claim for return, credit or refund. Refer "Dincel Construction Manual" for Installer's Dincel Product Acceptance Criteria" for detailed explanation.
- 6.6 The Customer is deemed to have read and understood the document titled "[Dincel Product Information](#)" ([download](#)) as it appears in the DCS website.
- 6.7 To the extent to which DCS is entitled to do so by law, its liability is limited at its option to the replacement of Defective Goods.
- 6.8 DCS shall not be under any liability for any injury, damage or loss resulting from any Defective Goods or from any associated work except to the extent that any statute applicable to these Terms and Conditions prevent the exclusion, restriction or modification of such liability.
- 6.9 The following paragraphs a) and b) apply to this clause 6 where the sale is subject to the Australian Consumer Law:
 - a) This warranty against defects is provided in addition to other rights or remedies you may have at law.
 - b) Our goods come with guarantees that cannot be excluded under the Australian Consumer Law. You are entitled to a replacement or refund for a major failure and for compensation for any reasonably foreseeable loss or damage. You are also entitled to have the goods repaired or replaced if the goods fail to be of acceptable quality and the failure does not amount to a major failure.

7. PRICE and PRICE VARIATION

- 7.1 Unless otherwise stated prices quoted are exclusive of GST and transportation costs.
- 7.2 All Government and applicable statutory charges, including GST will be borne by the Customer.
- 7.3 Unless otherwise stated on the relevant price list/invoice or statement the price does not include delivery or installation.
- 7.4 The price quoted may be subject to change due to, but not limited to, change in cost of material, supplier's costs and the currency fluctuations of the Australian Dollar. The price charged will be the price set by DCS in accordance with DCS's pricing and charges in effect at the date of collection/delivery. The project under construction may consist of a number of orders. The prices between orders may be varied.

8. TERMS OF PAYMENT

- 8.1 Deposit payment – The Customer pays an agreed deposit for Custom Lengths only) which can be in the form of 33% of the total value of each order OR one lump sum deposit payment, agreed between the parties in writing, for the nominated project/Customer. This applies to both COD and Credit Account Customers payments. Production/supply will not commence without the deposit payment for both COD and Credit Account Customers for Custom Lengths. The deposit payment in such case is therefore a confirmation of the Customer's order.
- 8.2 All terms of credit including credit limits relating thereto, are subject to these Terms and Conditions. The terms of credit may be varied by DCS at its sole discretion and any such variations will be communicated to the Customer in writing.
- 8.3 If DCS grants any credit facility or nominates any Credit limit, this is an indication only of its intention at the time. DCS can vary or withdraw any credit facility at its unfettered discretion, without liability to the Customer or any other party.
- 8.4 DCS may submit an invoice for Goods with delivery or at time of collection of Goods by the customer or their agent for COD Customers.
- 8.5 DCS extends credit, to approved Customers, on a strict, thirty (30) day basis from date of Statement. Statements are issued monthly. Statements are issued on the last day of each month for Credit Account Customers. The Customer must pay all amounts on the invoice issued by DCS (without reduction or set off) within the payment term agreed with DCS. Statement here refers to a summary of all transactions relating to the sale and purchase of Goods undertaken between the parties between defined dates (timeframe).
- 8.6 Credit card payments will attract a surcharge at DCS's sole discretion.
- 8.7 Credit approval is subject to DCS receiving a fully completed Application for Commercial Credit form and is subject to approval of a credit facility for the Customer by DCS and its Credit Insurance Underwriter.
- 8.8 Should accounts remain unpaid seven (7) days after the due date "Default" the account may be placed on "STOP TRADING" from that date without further reference/notice to the Customer until such time as the account is brought into terms. Should Default be made by the Customer in paying any sum due under this or any other contract as and when it becomes due, DCS may suspend all further deliveries until the Default has been made good or to repudiate the contract with regard to future deliveries. Continued breach of DCS's trading and payment terms may lead to the credit facilities being withdrawn. DCS reserves the right to demand full payment of the total debt owing and the right to refuse to offer further credit facility. DCS also reserves the right to report the Default to its Credit Insurance Underwriter.
- 8.9 If DCS's Credit Insurer cancels and or reduces the Credit facility made available to the Customer, then DCS reserves the right to immediately terminate the facility and demand immediate payment of any balance owing
- 8.10 If the Customer fails to pay, by the due date as specified under the terms for payment and/or under the Agreement any amount payable to DCS, interest will accrue and become payable by the Customer on the unpaid amount from the date of the issue of the invoice ("Invoice Date") to the actual payment date, at the rate of 0.5% per day, calculated on a daily basis, until such time as and when full payment is made by the Customer. Acceptance of payment in arrears or of partial payment shall not be deemed a waiver of the right to demand prompt payment in full or a waiver of any right or remedy that the DCS may have on any future occasion.
- 8.11 All outstanding monies and interest shall be paid by the Customer to the DCS, together with costs incurred by DCS in the collection of such outstanding monies, including but not limited to, fees payable to any mercantile agent and legal costs and expenses.

9. DELIVERY AND STORAGE

- 9.1 The Customer's order/s will be manufactured in accordance with the DCS Order Form and will be delivered to the agreed location on or about the agreed delivery date/s. Any date or time quoted for delivery is an estimate only. DCS shall not be liable for any loss or damage arising from the failure to deliver the order on or by the estimated delivery date.

- 9.2 When the Order specifies delivery to a nominated destination, DCS's obligation to deliver shall be discharged on arrival of the Goods at the Customer's nominated delivery destination, nominated transport company, nominated agent or the address appearing on the Order. The Customer shall unload the Goods on delivery. If the Customer is unable or unwilling to accept delivery of the Goods then DCS shall be entitled to the full payment for the Goods and to charge a fee for any delay experienced or arrange for the storage of the Goods at the risk and cost of the Customer including all transportation, storage and other consequential costs.
- 9.3 Where the Goods are to be delivered by partial shipment any failure on the part of DCS to deliver within the time stated shall not entitle the Customer to repudiate the Contract with regard to the balance remaining undelivered and any account due and payable.
- 9.4 Subject to the receipt and clearance of the deposit/full payment or approval of order and transportation availability, normal DCS lead times are:
- A **minimum of seven (7) working days** after the deposit payment (to be confirmed by DCS) for Custom Lengths of 110P-1, 155P-1 and 200P-1 profiles subject to availability and size of customer's order.
 - A **minimum of two (2) working days** (to be confirmed by DCS) for any Stock Length profiles subject to availability and size of Customer's order.
 - Up to **fifteen (15) working days** after the deposit payment (to be confirmed by DCS) for Custom Lengths of 275P-1 profiles.
- 9.5 Storage – Each produced Order must be cleared from DCS's factory within two (2) days (maximum) after the agreed delivery/collection date irrespective of all conditions including weather that may be applicable to the delivery address. If the Goods are not cleared within two (2) days, the Custom Length Goods produced for the Customer will be delivered to a storage space with all associated transportation and storage costs to be paid by the Customer. DCS shall not accept any liability for the Goods sent for storage. Storage fees will be charged at the rate of \$0.50 per day per lineal meter of the Product P-1.
- 9.6 Deliveries to be charged at the ruling rate of the date of delivery per truck load consisting of an 8m tray within a 55km radius of Erskine Park, NSW. If for any reason ordered Goods cannot be received and are returned for re-delivery by the construction site, even in the event of inclement weather, a re-delivery charge and storage fees will be payable by the Customer.
- 9.7 Delivery charges include first half hour waiting period on arrival. Any additional waiting time will be charged as extra at the rate of \$100.00 + GST per hour or part thereof.
- 9.8 It is the Customer's responsibility to provide a flat and clean area with timber sleepers placed at 1000mm (maximum) centres to receive the delivered Product. The Customer shall unload the Product upon delivery. The delivery trucks will not leave the public roads for drop-off.
- 9.9 Customers organising their own transportation are required to read and understand the [DCS Transport Information \(download\)](#) document which is available on the DCS website. Those terms form part of these Terms and Conditions.
- 9.10 Delivery to and collection of Goods by the Customer's agent, carrier or representative shall constitute delivery to the Customer.
- 9.11 All deliveries and pick up prices are ex-warehouse, unless otherwise agreed to by DCS in writing, and the Customer accepts all responsibility for deliveries and collection once they leave DCS's warehouse.
- 9.12 Freight costs and insurance are the responsibility of the Customer unless otherwise agreed between the parties.

10. INDEMNITIES, WARRANTIES AND AUTHORISATION

- 10.1 The Customer warrants that DCS shall be entitled to rely on all information supplied by the Customer as continuing up to and including the date of receipt of written notice from the Customer advising DCS of any change.
- 10.2 The Customer authorises DCS to verify and substantiate all information detailed in DCS's Application for Commercial Credit form.
- 10.3 If any of these Terms and Conditions or any part thereof is rendered illegal, then such term and condition or part thereof shall be severed from these Terms and Conditions and the validity of the remainder shall in no way be affected.
- 10.4 The Customer indemnifies DCS against any liability for any direct, indirect or consequential injury, loss or damage arising out of any act, default or omission of, or any representation made by the Customer, its agents or servants.
- 10.5 The Customer expressly acknowledges and agrees that it has not relied upon and DCS is not liable for any advice given by DCS, its agents or servants in relation to the suitability for any purpose of Goods or materials supplied by DCS.
- 10.6 The Customer acknowledges that to the extent DCS has made any representation which is not otherwise expressly stated in these Terms and Conditions, the Customer has been provided with an opportunity to independently verify the accuracy of such representation.

11. ORDER VARIATIONS

- 11.1 Alterations to Orders – Alterations to size, dimensions or physical property of Goods will not be accepted in regard to Orders which are either completed or in production.
- 11.2 Deferment of Delivery/Collection – where the Customer requests a deferment of delivery/collection, including any partial deferment of delivery/collection, of the Goods and such deferment is agreed by DCS, the date from which the delivery/collection is deferred shall be deemed to the date on which delivery/collection is made for the purposes of invoicing (invoice will be issued for the full value of the Order on the deemed date of delivery). From that date until the date of actual delivery/collection the Customer shall pay a storage fee and interest as determined by DCS based on the prevailing rates at the time.

12. RETURNS, RETURNS FOR CREDIT

- 12.1 The Customer purchases the Product and associated components with the understanding that DCS will not accept any unused DCS Product and no refunds will be made.

13. ALTERATIONS TO CONDITIONS

- 13.1 These conditions will not be varied unless DCS agrees to in writing.

14. GOVERNING LAW

- 14.1 All contracts between DCS and the Customer shall be governed by and construed in accordance with the laws of New South Wales, Australia. The Customer agrees to submit to the non-exclusive jurisdiction of the New South Wales Courts and courts of appeal therefrom for all purposes of or in connection with such Contracts.

15. FORCE MAJEURE

- 15.1 DCS will not be liable for any loss incurred as a result of delay or failure to make any supply of Goods or Services or to observe any of these Terms and Conditions due to an event of force majeure, being any cause or circumstance beyond the reasonable control of DCS, including but not limited to, any lack of production capacity or raw materials, strikes, lock-outs, labour disputes, fires, floods, acts of God or public enemy, malicious or accidental damage, delays in transport, breakdowns in machinery or restrictions or prohibitions by any government or any semi-government authorities or embargoes. During the continuance of an event of Force Majeure DCS's obligations under these conditions will be suspended. The Customer shall not be relieved of any obligations to accept and pay for Goods where the supply of Goods is delayed by the events of force majeure.

16. RETENTION OF TITLE & TERMINATION

- 16.1 Legal and equitable ownership of the Goods will not pass to the Customer until the Customer has paid (cleared funds) to DCS, the invoiced amount(s) for the Goods due in the Customer's possession at time of payment.
- 16.2 Unless otherwise defined in these terms, capitalized terms and expressions used in these Terms and Conditions have the same meaning as they have in the Personal Property Securities Act 2009 (PPSA)
- 16.3 The Customer agrees with DCS that they will treat DCS's interest in the Goods as a Security Interest, which will be a continuing and subsisting security with priority over a registered general security and any unsecured creditors.

- 16.4 Until such time payment is made by the Customer, the Customer shall, at the direction of DCS, store the Goods separately and in a proper and workmanlike manner subject only to its right to deal with the Goods in the ordinary course if its business and any monies received as a result of such dealing shall be held by the Customer for the benefit of DCS.
- 16.5 DCS may at any time, at its option, without notice to the Customer and without prejudice to any other rights which it may have as against the Customer, terminate in writing any contract connected with the Goods and enter upon any premises owned or occupied by the Customer where DCS reasonably believes the Goods may be stored, repossess the Goods without liability for any damage caused, and subsequently dispose of the Goods at DCS's discretion if:
- a) Payments of outstanding invoices are not made by the Customer in accordance with these Terms and Conditions and any other written arrangement between DCS and the Customer.
 - b) DCS receives notice of or reasonably believes that:
 - a. A third person may attempt to levy execution against the Goods;
 - b. The Customer is insolvent (within the meaning of the Corporations Law) or bankrupt; or
 - c. The Customer has entered into any arrangement or composition with its creditors, gone into liquidation, or has appointed a receiver, a receiver and manager or administrator.
- 16.6 If, in addition, any of the Goods still in possession of the Customer exceeds those Goods in respect to which payment is still owed by the Customer to DCS, at its absolute discretion DCS shall have the right to determine in relation to which Goods DCS retains ownership.
- 16.7 The sale of the Goods by the Customer to a third party prior to the passing of title to the Customer will be deemed to have been made by the Customer as agent for DCS, and the sale proceeds sufficient to cover the unpaid price of the Goods shall be held in trust for DCS as its property. If the Product/Goods is affixed to other material, the totality thereof shall be the sole and exclusive property of DCS until payment has been made in full to DCS. Should the other material or part thereof be the property of any other party other than the Customer, the totality shall be deemed to be owned as tenants in common with other such party until payment has been made in full to DCS.

17. PROPERTY AND RISK

- 17.1 The title in respect to the Goods supplied will not pass to the Customer until such time as full payment has been received by DCS. The sale of the Goods by the Customer to a third party prior to the passing of title to the Customer will be deemed to have been made by the Customer as agent for DCS, and the sale proceeds sufficient to cover the price of the Goods shall be held in trust for DCS as its property. The risk in the Goods shall pass to the Customer upon delivery of the Goods to the Customer, its agent or its nominated transport company. In the event of collection of Goods by the Customer or its agents or transport company, the risk in the Goods shall pass immediately upon acceptance of the Goods at the DCS premises. The Customer is liable for any loss or damage to the Goods upon passing of the risk in the Goods
- 17.2 In the event of the Customer having a bankruptcy notice issued against them, or in the case of a Company, if an Administrator, Liquidator, Receiver or Receiver Manager has been appointed, and in the event of Goods having been supplied by DCS and full payment for such Goods not having been received by DCS, then DCS shall have the full and unfettered right to enter onto the premises or yard or property or building site of the Customer at any time and take possession of such goods in respect of which payment has not been made to DCS. Ownership of such Goods at all times remains vested in DCS.

18. RIGHT OF ENTRY

- 18.1 The Customer irrevocably grants to DCS the right to enter on the Customer's property or premises, without notice, and without being in any way liable to the Customer or to any third party, if DCS has cause to exercise any of DCS's rights under these Terms and Conditions or under section 110 of the PPSA, and the Customer indemnifies DCS from any claims made by any third party as a result of that exercise.
- 18.2 DCS reserves the right to register their interest as a Security Interest on the "Personal Property Security Register" (PPSR) in accordance with the PPSA.

19. PERSONAL PROPERTY SECURITIES ACT 2009 (PPSA)

- 19.1 The Customer acknowledges and agrees that:
- a) These Terms and Conditions constitute a security agreement for the purposes of section 20 of the PPSA and that a Security Interest exists in all Goods (and their proceeds) previously supplied by DCS to the Customer and in all in future Goods (and their Proceeds).
 - b) The Customer has received valuable consideration from DCS in DCS providing Credit to the Customer under these Terms and Conditions.
- 19.2 Further, in consideration of DCS supplying the Goods to the Customer, at the Customer's request, the Customer, by signing these Terms and Conditions:
- a) Grants to DCS, at DCS's discretion, a Security Interest or Purchase Money Security Interest ("PMSI") in the Goods;
 - b) Agrees that any of the Goods or Proceeds of sale of the Goods coming into existence after the date of these Terms and Conditions will come into existence subject to the Security Interest or PMSI granted in these Terms and Conditions;
- 19.3 The Security Interest or PMSI has attached or will attach to all Goods supplied now or in the future to the Customer by DCS when the Customer takes possession of the Goods and that the attachment of the Security Interest or PMSI has not in any way been deferred or postponed from the date of these Terms and Conditions.
- 19.4 The Customer is to take all steps, will execute all necessary documents and do such further acts as may be required by DCS to register on the Personal Property Securities Register (PPSR) the Security Interest granted to DCS under these Terms and Conditions pursuant to the requirements of the PPSA to ensure that:
- a) these Terms and Conditions or any Security Interest or PMSI arising under them, are enforceable as against the Customer or any third party; and
 - b) Protect, perfect, record, or better secure the position of the DCS under these Terms and Conditions as a first ranking security.

20. REGISTRATION AND NOTICES UNDER THE PPSA

- 20.1 DCS reserves the right to register a financing statement on the PPSR in respect of any Goods supplied by DCS to the Customer under these Terms and Conditions and in respect of which Credit has been extended by DCS to the Customer.
- 20.2 The cost and expense of registering a financing statement or a financing change statement is to be paid by the Customer and may, where applicable, be invoiced against the Customer's account with DCS.
- 20.3 The Customer waives the right to receive a copy of any notice, verification statement confirming registration of a financing statement or a financing change statement relating to the security interest or PMSI under these Terms and Conditions, unless the notice or statement is required by law and cannot be excluded; and agrees to comply with any notice from DCS under these Terms and Conditions at its own cost and expense.
- 20.4 The Customer agrees not to allow any person to register a financing statement over any of the Goods supplied to the Customer by DCS without the prior written consent of DCS and that the Customer must immediately notify DCS if it becomes aware of any persons taking steps to register a financing statement in relation to the Goods.
- 20.5 The Customer agrees to perfect and maintain any Security Interest or PMSI that it may have in the Goods under the PPSA.

21. NO ACCESSIONS OR COMMINGLING OF GOODS

- 21.1 The Customer must not allow the Goods to become accessions or commingled with other goods unless DCS has first perfected any Security Interest or PMSI that DCS has in relation to the Goods.

22. PERFECTION

- 22.1 If DCS perfects any Security Interest or PMSI that DCS has in relation to the Goods, the Customer must not do anything that could materially adversely affect DCS's business; or in the opinion of DCS, DCS's security position under these Terms and Conditions.

23. INTELLECTUAL PROPERTY AND ADVERTISING RIGHTS

- 23.1 In these Terms and Conditions, "Intellectual Property rights" include the full benefit of any rights in any copyright, trademark, registered design, patent, trade and business names, know-how, inventions, improvements, discoveries and confidential processes and includes without limitation artistic works, images, illustrations and photographs and any adaptation or concept relating to it held or owned by DCS, or licensed to DCS or claimed to be held or owned by DCS or licensed to DCS. The Customer warrants and acknowledges that it will not use any Intellectual Property rights without the written consent of duly authorised officer of DCS.
- 23.2 Where Special Goods are produced and supplied by the DCS which are their propriety products, such Goods are acknowledged to be DCS's property and protected by DCS's Intellectual property rights and such Goods can only be used by the contracted party and may not be resold to any other party without the express written permission of the DCS. Special Goods include but are not limited to proto-types, unique profile designs, proprietary products and those Goods that, at DCS's sole discretion, not deemed to be standard products.
- 23.3 In the event of an Administrator, Liquidator or Receiver/Manager being appointed to the Customer, the proprietary products cannot be re-sold and must be returned to the DCS.
- 23.4 In the event that the Administrator, Liquidator or Receiver/Manager sells or otherwise disposes of such Goods, then DCS shall hold that party liable for the full costs of those Goods.
- 23.5 DCS is not liable for any infringement or unauthorised use of any intellectual property rights arising from these Terms and Conditions. If any dispute or claim is made in respect of any infringement or unauthorised use of intellectual property rights, DCS reserves the right to terminate the any applicable agreement by notice to the Customer and without liability to the Customer or any other person.
- 23.6 The customer agrees to and consents to DCS displaying a banner or sign advertising DCS, at the front of the construction site in a position visible to the public until completion of construction.

24. PERMITTED USE

- 24.1 The purchaser acknowledges that DCS has agreed to sell the Product to the purchaser on the strict understanding that the Product will be used in Australia only; that the purchaser will not on-sell or gift the Product outside of the Australian territory. Sale and export rights of the Product are the sole and exclusive rights of DCS. The purchaser agrees to these terms of sale and further agrees that DCS will be entitled to damages for any breach of the same.

25. AGREEMENT

- 25.1 The Customer agrees that they have read and understood the conditions of sale contained and that by placing his first Order for DCS Product they agree to be bound by each and every one of the said conditions for such first and all subsequent orders whether the same relates to the project or any subsequent job or project.

26. PAYMENTS MADE IN RESPECT OF THE GOODS

- 26.1 Despite any statement to the contrary by the Customer, every payment to DCS in respect of the Goods must be taken as a payment:
- firstly, of the amounts held by the Customer in trust or subject to a security interest, to the extent that the security interest is not a PMSI;
 - secondly, of amounts subject to a security interest, to the extent that it is a PMSI;
 - thirdly, for any Goods that the Customer has sold but for which it has not received the proceeds; and
 - fourthly, for whatever Goods the Customer has not sold as DCS elects.

27. CONFIDENTIALITY

- 27.1 Except as required by law, these Terms and Conditions subject to the PPSA, DCS and the Customer agree to treat these Terms and Conditions as confidential. The Customer warrants that it will not disclose Confidential Information of DCS to any person or entity. Confidential Information includes but are not limited to Intellectual Property, know-how, trade secrets, signs, distinctive marks, models, policies, inventions, methodologies, financial and technical data, and commercially valuable information.

28. TRUST AND TRUSTEES

- 28.1 Where the Customer acts on behalf of a Trust, the following are to be complied with:
- The Customer agrees to produce a stamped copy of the Trust deed (inclusive of all amendments) upon DCS's request;
 - The Customer warrants that they hold full power and authority to act on behalf of the Trust in entering this Trust;
 - The Trust shall be bound by these Terms and Conditions both personally and as Trustee, irrespective of whether the Customer discloses to DCS that they are a Trustee at the time of entering into any credit agreement with DCS.

29. PRIVACY POLICY

- 29.1 DCS's may collect and make use of your personal information for purposes including:
- to process and administer your dealings as a Customer, including assessing your credit worthiness;
 - to provide you with the Goods and Services you have requested and assisting you with further relevant information including Goods/Product related information; and
 - to administer the transactions contemplated by the Terms contained in this document.
- 29.2 DCS will generally
- use personal information provided to it for the purposes relating to the terms of this document;
 - use personal information collected by it in accordance with its Privacy Policy and the Privacy Act 1988 (Cth) (the "Privacy Act"); and
 - not sell, trade, give or pass on to any third party any personal information unless such a disclosure is contemplated by and directly related to the purpose outlined by the terms of this Agreement, or the Customer consents to such a disclosure or such disclosure is required to do so by law.
- 29.3 Customer therefore authorises DCS to disclose Customer's personal information to third party contractors and service providers that assist DCS operate its business and assist DCS fulfil the terms of this agreement such as contractors and service providers involved in services including but not limited to the processing of orders, order fulfilment and the collection of outstanding debts.
- 29.4 Customer warrants that it shall comply with the provisions of the Privacy Act and shall not (as far as practicable) knowingly do anything or permit anything to be done which might lead to a breach of any such legislation.